

# Product Description

Product model: ZT-MS-H015

## 1. Product brief

Product name	RFID label / wet inlay / dry inlay
Product model	ZT-MS-H015
Product usage	Item identification and tracing, warehousing management, logistics management, production line management, etc.

## 2. Antenna



## 3. Product size (label size: 35\*18mm; antenna size: 31\*14mm)

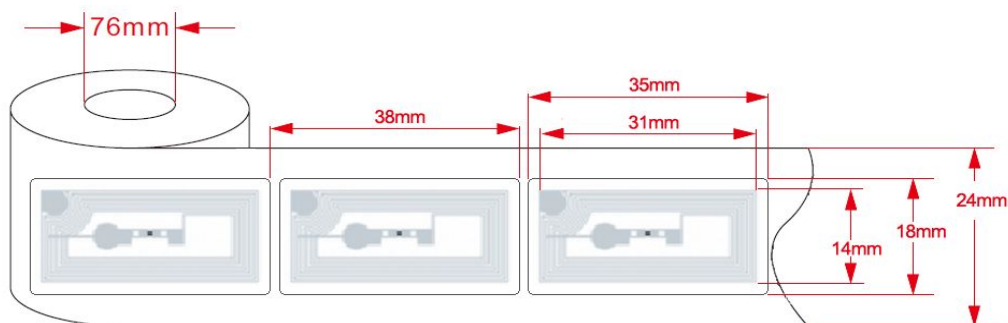

## 4. Electronic properties

Chip	ICODE SLIX / FM13HF02N
Frequency	13.56MHz
RF standard	ISO15693

## 5. Product composition

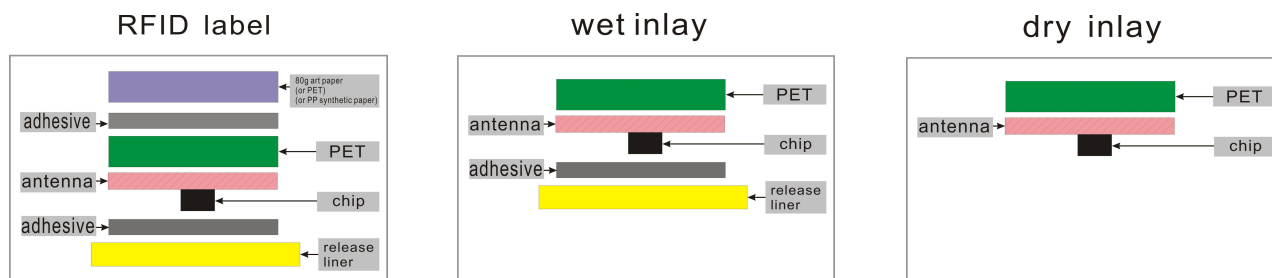

## 6. Use warning

6.1

Do not use if the black dot is marked as defective.  
The location of the defective product is shown on the right.

6.2

Pay attention to waterproof when handling and using.  
Do not violently impact, squeeze or bend.

6.3

Operating temperature / humidity: -40~70°C / 20% ~ 90% RH.

Storage temperature / humidity: -20~50°C / 20% ~ 90% RH (no condensation).

Recommended storage temperature / humidity: 20~30°C / 50%.

Marking of defective products: black ink dots, diameter: 3mm

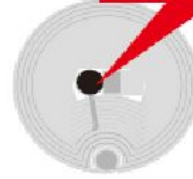

## 7. packaging

Quantity per roll: Customizable

Packaging method:

- 1) Use a stabilizer to protect the IC and the antenna.
- 2) Packed in pearl cotton and anti-static plastic bags, waterproof, anti-collision, anti-static.
- 3) Use standard carton packaging.

